

OWNER'S MANUAL

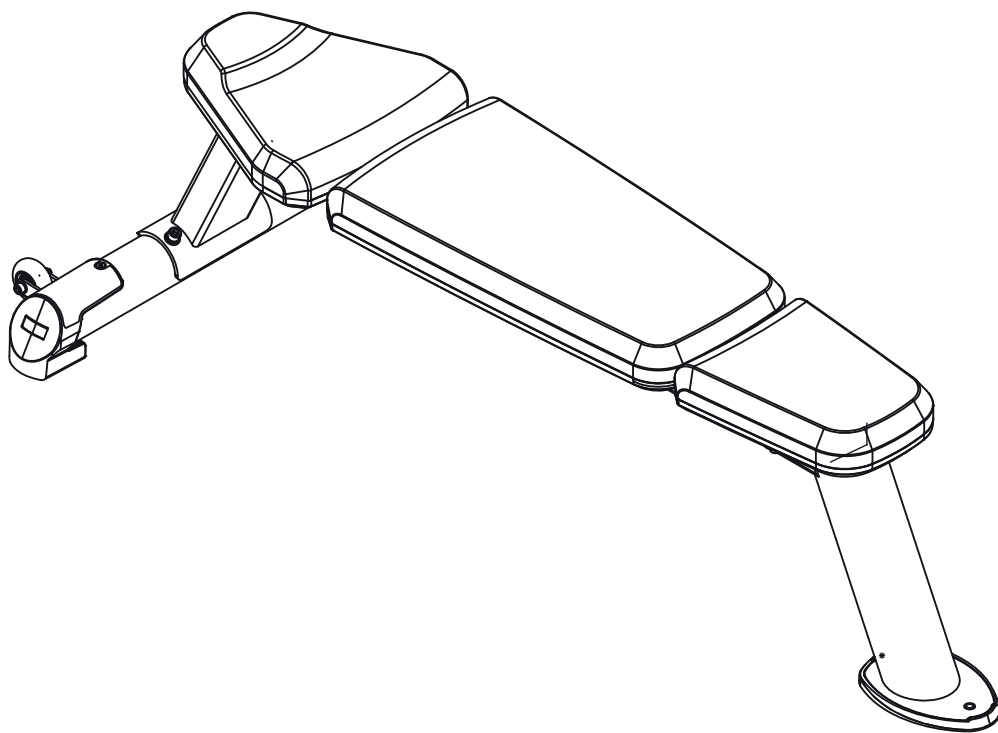

Flat Bench



Cautions

In order to avoid human injuries and property damages, before the use of this series equipment, please read the following important notices.

1. Before use of the equipment please read this Owner's Manual carefully. The equipment should be assembled and used strictly following the relevant instructions in this manual, and can not change any of its components or disassemble it freely.
2. It should be ensured that all users have been fully aware of the safety warnings and precautions before they exercise on the equipment.
3. Too loose-fitting clothing can not be worn, and sports shoes should be put on while exercising.
4. The equipment should be carefully examined before training. If there is damage, please do not use it and do not try to repair it by yourself. Please contact your supplier in time. It is necessary to inform after-sales service personnel as soon as possible to get the machine repaired.
5. The equipment should be placed indoors, and make sure that the ground is flat, and there are enough space around the equipment for user to exercise on the machine freely.
6. Child and pet are not allowed to be too close to the equipment while it is in using.
7. If exerciser feels dizzy or physical pain while training he or she should stop exercising immediately and consult a doctor.
8. The equipment should be used in a well defined place and under well managed and monitored way of the equipment owner.

Before using the equipment please consult your physician and fitness expert, and must be sure to read all the specifications in this owner's manual. Manufacturer will not be held responsible for any personal injury and property loss resulted from the incorrect use of the products.

Fitting Instructions

1. When strip off the wrappage around the surface of equipment, should be careful, do not hurt the machine with knife scratches on the surface.
2. When moving this equipment, a sufficient number of personnel should be used to prevent the equipment from collision, or to avoid the injuries caused by personnel shortage.
3. Prior to installation of the equipment, make sure that all the parts are complete, no missing hardware.
4. When install the equipment, should have two or more persons working together to ensure the accurate location of parts assembly.
5. When install the equipment should pay attention to the assembly instructions to prevent component fitting to a wrong place or some components being omitted.
6. The suitable installation tools should be used to avoid the equipment damages or human injuries caused by the use of inappropriate tools in the installation process.
7. If need to move equipment, the movement must be after the completion of installation. The equipment can not be moved when the installation process hasn't finished or locking nut hasn't been tightened up.
8. Attention should be paid to the sequence of fastening locking nut, when the overall installation of the equipment is not finished, should not tighten up the nut that is being installed. After the whole machine is properly fitted together, the locking nuts can be tightened up one by one.
10. After the completion of installation, start the initial trial of the equipment with gentle force. Make certain that the equipment is without any abnormality before normally use the machine. If something unusual is found with the equipment that, it is necessary

to check the equipment carefully, identify the problems and reinstall it.

Warranty

***Ten years: Main Frames**

***One year: Bushings, Pivot bearings, guide rods, Weight plate, cams, swivel welding parts, Pull-pin components**

***Half year: Finish, rubber grips, belt, cables.**

***Three Months: upholstery**

Assembly step 1

Step	No.	Description	Specifications	Qty
1	6	Hex socket head cap screw	M8*40	6
	7	Hex socket head cap screw	M10*30	2
	8	Spring washer	M8	6
	9	Spring washer	M10	2
	10	Plain washer	$\Phi 16*\Phi 8.4*1.6$	6
	11	Plain washer	$\Phi 20*\Phi 10.5*2$	2
	17	Hex socket head cap screw	M8*85	2

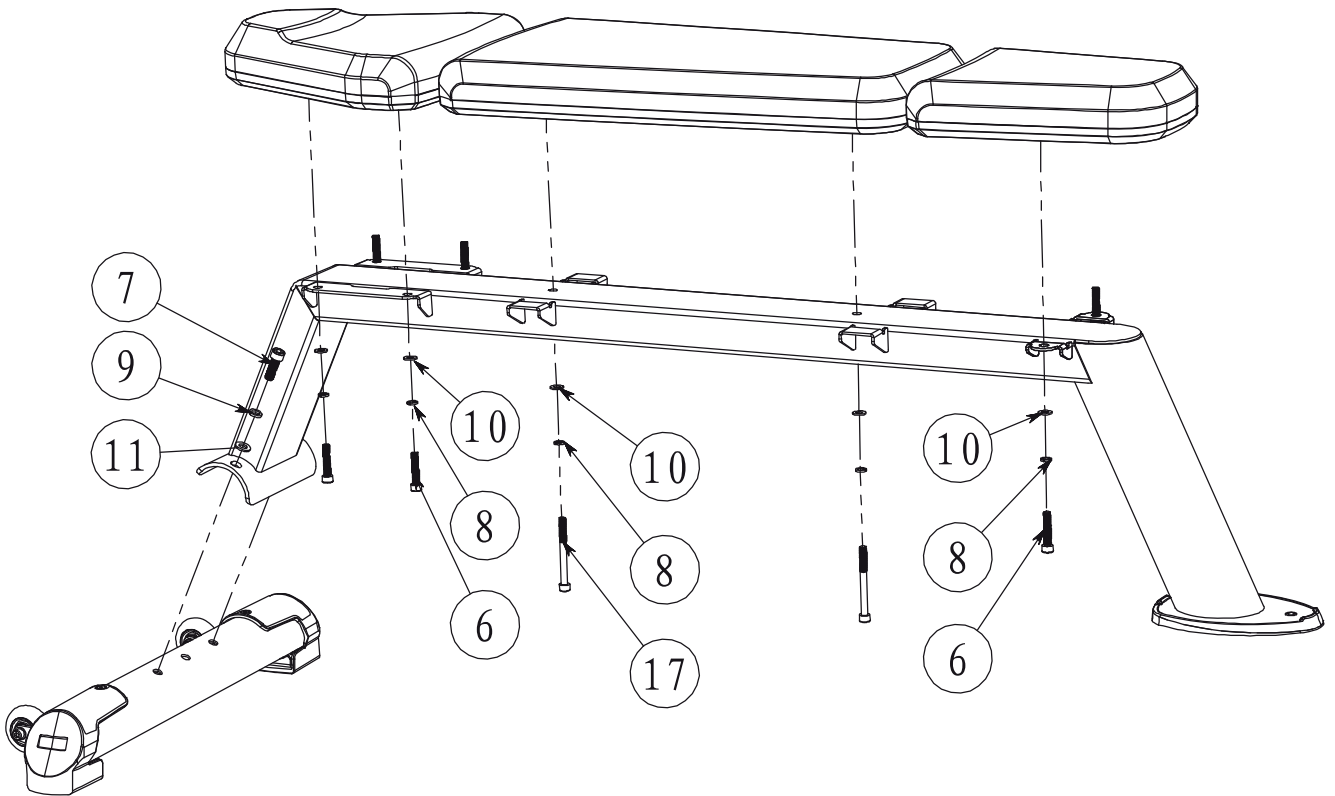

Exploded View

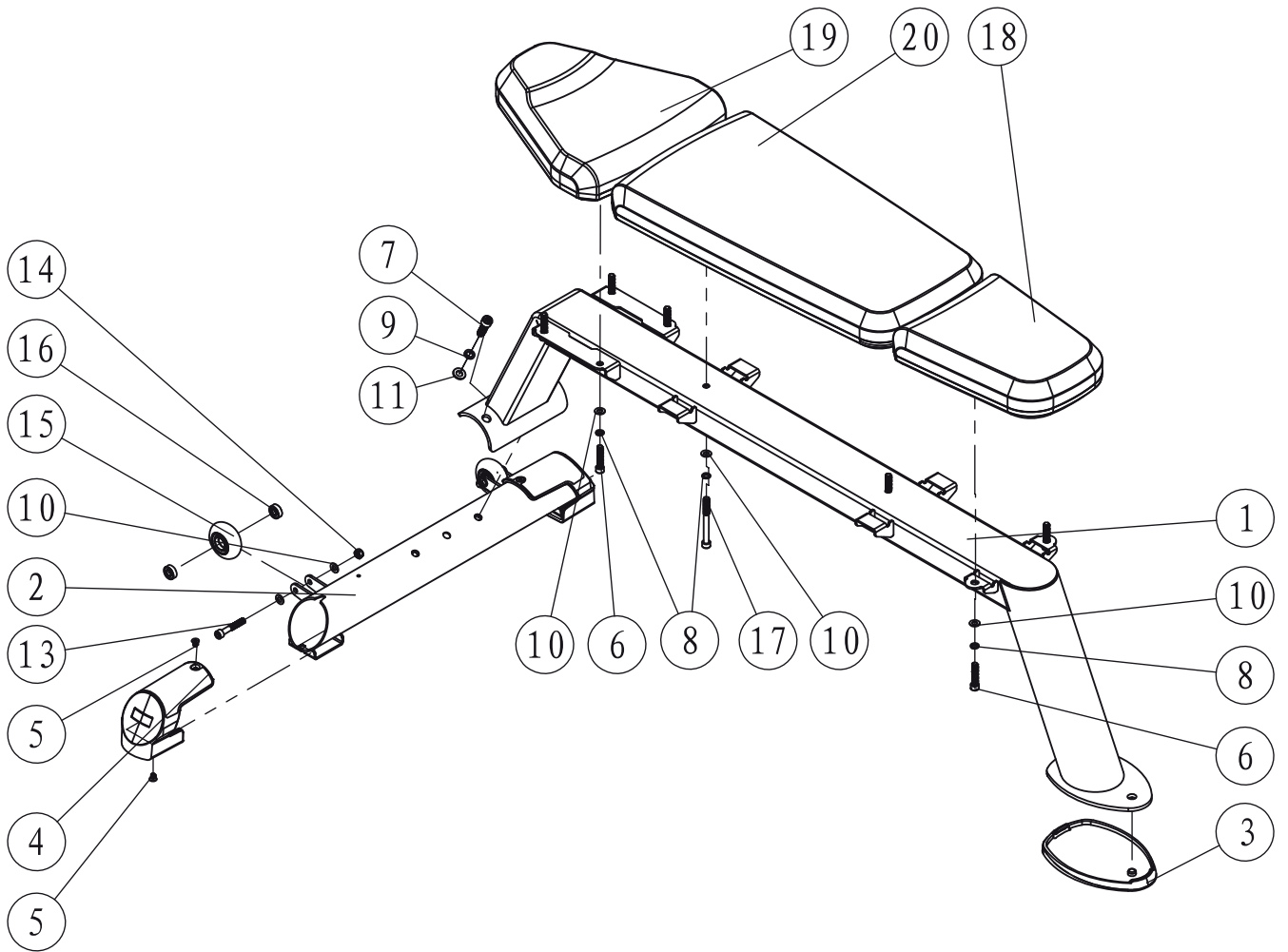

Exploded List

No.	Description	Specifications	Qty
1	Backrest cushion frame		1
2	Foot frame		1
3	Rubber mat		1
4	Affixed to shackle		2
5	Countersunk hex socket screws	M6*10	4
6	Hex socket head cap screw	M8*40	6
7	Hex socket head cap screw	M10*30	2
8	Spring washer	M8	8
9	Spring washer	M10	2
10	Plain washer	Φ16*Φ8.4*1.6	12
11	Plain washer	Φ20*Φ10.5*2	2
12			
13	Hex socket head cap screw	M8*50	2
14	Nylon insert lock nut	M8	2
15	Roller train		2
16	Deep Groove Ball Bearing		4
17	Hex socket head cap screw	M8*85	2
18	Head pad		1
19	Seatpad		1
20	Back pad		1
21			
22			
23			
24			
25			
26			
27			
28			
29			
30			
31			
32			
33			
34			
35			
36			
37			
38			
39			
40			
41			
42			

Maintenance Attentions

Daily Maintenance (Basic Maintenance)

1. Clean the seat pad, back pad and cushion with warm water and soft cloth in order to avoid the sweat erosion to these component.
2. Clean the frame with warm water and soft cloth.
3. Cleaning chrome plated parts: wipe them with alcohol moistened soft cloth.

Further Maintenance

1. Check whether bolts on basic frame become loose, springs have damaged and the tightness of drive cable.
2. Check, if there is rust or paint loss on main frame and basic rack, clean out rust by sand paper, and then cover it with same color paint from the same supplier.
3. Clean and lubricate every bearing, and keep equipment work smoothly.
4. Check whether the rubber gasket is broken.
5. Check bolts and fixing parts. Wipe them with alcohol and anticorrosive oil.